

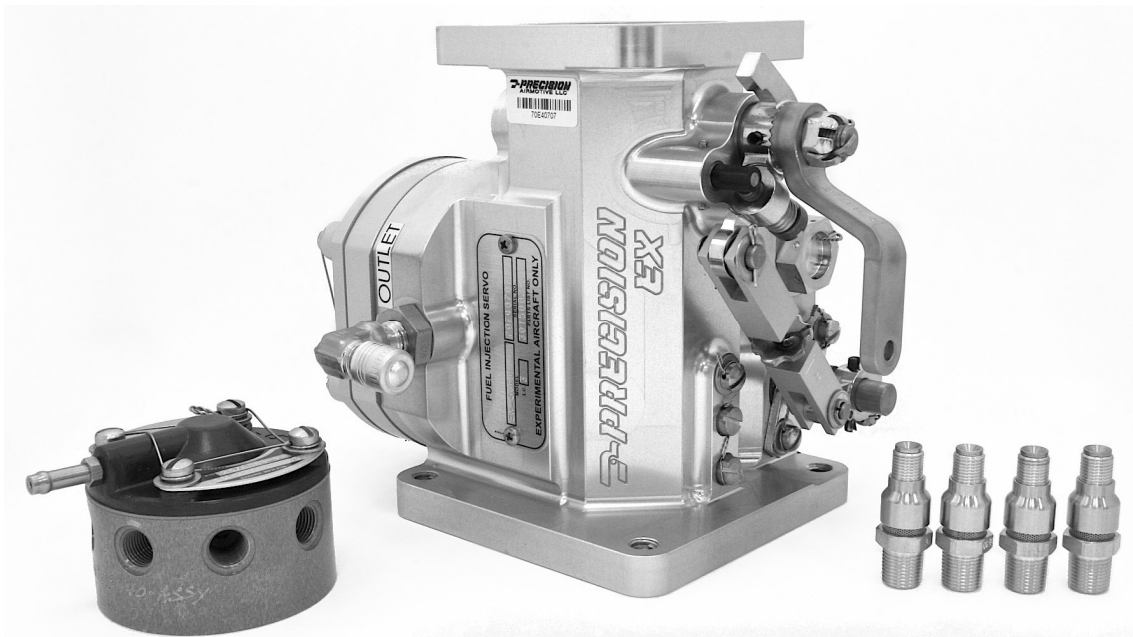

# INSTALLATION AND DETAIL SPECIFICATIONS

FOR THE

## SILVER HAWK EX<sup>®</sup> EX-5VA1<sup>®</sup> SERVO KIT







## **INSTALLATION AND DETAIL SPECIFICATION** **EX-5VA1<sup>®</sup> FUEL INJECTION SERVOS**

Precision Airmotive LLC fuel systems are produced using the highest quality materials and components. This gives the user the assurance that their fuel injection system has been manufactured and tested under the strictest quality standards in the industry.

We take great pride in the reputation our products and services have earned through years of performing safely and dependably under all flying conditions.

The Silver Hawk EX<sup>®</sup>, non-certified fuel injection system is proven technology drawn from decades of fuel metering engineering by Precision Airmotive LLC. Manufactured as experimental, this Silver Hawk EX<sup>®</sup> kit provides experimental aircraft with precise, dependable, and reliable fuel metering.

Only Precision Airmotive LLC supplies the latest training manuals, technical, and engineering support.

If you have any questions, please call our product support department at 360-651-8282, or visit our website: <http://precisionairmotive.com>

Thank you for choosing a Precision Airmotive LLC product.

### **WARNING:**

The use of unauthorized parts in any system can cause product malfunctions, which could result in damage to, or destruction of, equipment and injury to and/or death of personnel. Use only Precision Airmotive LLC replacement parts as specified in the Illustrated Parts List.

#### PERMISSION TO REPRINT

PERMISSION TO REPRINT THIS “INSTALLATION AND DETAIL SPECIFICATIONS FOR THE SILVER HAWK EX<sup>®</sup> EX-5VA1<sup>®</sup> SERVO KIT” DOCUMENT IS GRANTED, SO LONG AS CONTENT OF INFORMATION REMAINS INTACT AND APPROPRIATE CREDIT IS GIVEN.



<http://precisionairmotive.com>  
17716 48<sup>th</sup> Drive NE, Arlington, WA 98223  
Telephone (360) 651-8282, Fax (360) 651-8080



**INSTALLATION AND DETAIL SPECIFICATION**  
**EX-5VA1<sup>®</sup> FUEL INJECTION SERVOS**

**TABLE OF CONTENTS**

<b>1.</b>	<b>Purpose</b>	<b>1</b>
<b>2.</b>	<b>Description</b>	<b>1</b>
<b>3.</b>	<b>General Specifications for EX-5VA1<sup>®</sup></b>	<b>1</b>
<b>4.</b>	<b>Installation Requirements</b>	<b>2</b>
<b>5.</b>	<b>Environmental Requirements</b>	<b>2</b>
<b>6.</b>	<b>Configuration Adjustment</b>	<b>3</b>
<b>6.1.</b>	<b>Throttle and Mixture Control Levers</b>	<b>3</b>
<b>6.2.</b>	<b>Fuel Inlet and Alternate Inlet Fittings</b>	<b>3-4</b>
<b>6.3.</b>	<b>Servo Fuel Outlet and Alternate Outlet Fittings</b>	<b>4</b>
<b>7.</b>	<b>Starting Procedure</b>	<b>4</b>
<b>8.</b>	<b>Idle Speed and Idle Fuel Flow</b>	<b>4</b>
<b>9.</b>	<b>Economy Cruise</b>	<b>4</b>
<b>10.</b>	<b>Rated RPM Fuel Flow Adjustment</b>	<b>4</b>
<b>11.</b>	<b>Fuel Leaks</b>	<b>4</b>
<b>12.</b>	<b>Maintenance, Repair, and Overhaul</b>	<b>5</b>
<b>13.</b>	<b>Drawings</b>	
	<b>Fuel System Layout</b>	<b>5</b>
	<b>Nozzle</b>	<b>6</b>
	<b>Flow Divider</b>	<b>7</b>
	<b>Servo</b>	<b>8</b>
<b>14.</b>	<b>Torque Specifications</b>	<b>9</b>
<b>15.</b>	<b>Troubleshooting Tables</b>	<b>10-11</b>
<b>16.</b>	<b>Troubleshooting Run Up Sheet</b>	<b>12</b>
<b>Appendixes</b>		
	<b>Appendix A: Starting Procedure</b>	<b>13</b>
	<b>Appendix B: Idle Speed &amp; Mixture Adjustments for Fuel Injection Systems</b>	<b>14-16</b>



# INSTALLATION AND DETAIL SPECIFICATION

## EX-5VA1<sup>®</sup> FUEL INJECTION SERVOS

- 1.0 Purpose.** This specification provides a description of the EX-5VA1<sup>®</sup> mechanical fuel injection servo kits and the applications where they can be used. It also outlines the requirements for new installations.
- 2.0 Description.** The kit consists of a servo, flow divider, and nozzles.
  - 2.1 The EX-5VA1<sup>®</sup> mechanical fuel injection servos are based on the principle of measuring airflow to establish the correct fuel flow. A venturi is used to measure the airflow and create an air force proportional to airflow. An in-line diaphragm type regulator is used to convert an air force into a fuel force. The fuel force is applied across a fuel metering section and makes fuel flow proportional to airflow. The servo is the primary component used in the fuel injection system and performs all functions required to establish fuel flow volumes.
  - 2.2 The flow divider is used to distribute the metered fuel flow from the servo to the nozzles. The flow divider controls how much fuel goes to each nozzle from idle to about 25% horsepower. Above this power, the fuel distribution is managed by the nozzles.
  - 2.3 A fuel nozzle is installed into each one of the engine's cylinder intake runners for equal cylinder-to-cylinder fuel distribution. The nozzles incorporate an air bleed hole that is vented to atmospheric air. This hole is used to emulsify and atomize the fuel as it enters into the intake runner.
- 3.0 General Specifications for EX-5VA1<sup>®</sup>**
  - 3.1.1 Designed for engines that make roughly 160-260 horsepower.
  - 3.1.2 Can be adapted to work on both turbo and non-turbo engines.
  - 3.1.3 Easily installed on Lycoming's 320, 360, 390, some 540s, and Continental O-470. Servo can be installed on engines other than Lycoming and Continental with customer supplied intake manifold adapters. The installation drawing in this manual shows the bore size and bolt patterns for the air box and manifold sides of the servo.
  - 3.1.4 Idle speed and mixture are adjustable for smooth idle.
  - 3.1.5 Fuel distribution is optimized because the fuel is sprayed into each cylinder's intake port by means of a fuel nozzle. This gives each cylinder the same amount of fuel.
  - 3.1.6 A mixture control lever is used for leaning the fuel flow during cruise or during high altitude operation.
  - 3.1.7 No throttle fly or venturi carburetor icing. Fuel is **NOT** sprayed in these areas but into the intake manifold ports.
  - 3.1.8 Fully aerobatic capable without any modifications. However, fuel pressure to the servo must be maintained.
  - 3.1.9 The mechanical fuel injection system consisting of three primary components: EX-5VA1<sup>®</sup> throttle body servo, flow divider, and fuel nozzles.
  - 3.1.10 Approximate combined weight for the servo, flow divider, and four nozzles is 6.06 pounds with the servo being 5.25 pounds.



# INSTALLATION AND DETAIL SPECIFICATION EX-5VA1® FUEL INJECTION SERVOS

## 4.0 Installation Requirements

Dimensional: See installation drawings for representational information. Other configurations are available for the selection and orientation of fuel fittings and control levers. Contact Precision Airmotive LLC Product Support for specifics.

Servo Fuel Inlet Fitting: Flared AN#6 (9/16-18)

Servo Fuel Outlet Fitting: Flared AN #4 (7/16-20)

Fuel Pressure: Nominal: 20-50 psig relative to airbox or upper deck pressure

Minimum Operating: The minimum operating pressure shall be determined by installation specific testing.

Max Operating: 80 psia max

Max Momentary Peak: 140 psia max

Fuel Filtration: The fuel supplied to the servo shall be filtered to 32 micron nominal. This filtration may occur prior to the engine driven pump, but all other pumps and valves shall be upstream of the filter.

Fuel Inlet & Outlet Lines: There are several options for fuel lines. They can be acquired from aircraft component suppliers. The fuel line should be designed for fuel, rated at 300°F or higher, and must be fire sleeved (or have an integral fire sleeve) and be able to handle 1000 psi.

Flow Divider: A list of available fittings and nozzle fuel lines can be found at <http://www.precisionairmotive.com>

Fuel Temp: 120°F recommended max at inlet to servo to minimize vapor formation downstream of the servo. Fuel temperatures upstream of the servo must be low enough to prevent vapor formation in the fuel lines. It is assumed that temperatures may exceed the above listed temperatures under some conditions, but these temperatures may result in degraded performance at low engine speeds.

Inlet Air Temp: The induction air temperature measured at the inlet to the servo shall not exceed 400°F.

Inlet Air Filter: The air inlet to the servo needs to be filtered, contact the airplane kit supplier for the appropriate filter. An alternate air door must be part of the air inlet design. It is needed if the air filter is plugged by icing or by some other means.

Orientation: The servo may be installed in any orientation.

## 5.0 Environmental Requirements

Operating Temperature: -65°F to 300°F

This temperature shall be measured on the exterior of the throttle body adjacent to the outlet port on the valve body side of the servo.



## INSTALLATION AND DETAIL SPECIFICATION EX-5VA1<sup>®</sup> FUEL INJECTION SERVOS

**6.0 Configuration Adjustment.** Details on what can be changed regarding the fuel inlet and outlet fittings and the throttle and mixture levers are mentioned. See the installation drawings in this manual for the locations of where these components exist on the servo.

### 6.1 Throttle and Mixture Control Levers

- 6.1.1 The throttle and mixture levers can be removed and rotated to different angles to accommodate aircraft needs. The levers can even be swapped.
- 6.1.2 **The throttle lever** is held on with a castellated nut P/N 900848 and cotter pin P/N 901209K1. Whenever the throttle lever is moved or changed the nut must be torqued properly and a **new** cotter pin used. See torque specification table for torque values.
- 6.1.3 The **mixture control lever** is held on with an elastic stop nut P/N 187313. If the mixture lever is moved or changed a **new** nut must be installed and torqued to value noted in the torque specification table.
- 6.1.4 The dimensions for the various levers can be found on the Precision Airmotive LLC web site in the Silver Hawk EX<sup>®</sup> support area.

### 6.2 Fuel Inlet and Alternate Inlet Fittings

- 6.2.1 The servos have two possible fuel inlet ports. One of the ports will have a flared AN #6 type fuel fitting installed. This port is called the “Inlet”. The other port is called “Alternate Inlet” and it is plugged with a fitting and safety wired to the servo body.
- 6.2.2 The inlet and alternate inlet fittings can be swapped or changed, but it must be done correctly **to ensure flight safety**. There is a fuel filter inside of the servo. Both of the fittings are specially designed to work together to hold the filter in the proper orientation. **Only** use Precision Airmotive LLC parts; using any other parts including standard AN parts can damage the filter or servo body causing loss of fuel flow and a flight safety problem. The part numbers for these are called out on the drawings. The following procedure defines how to properly swap fitting locations or change fittings.
  - 6.2.2.1 Remove the inlet fitting **first**, then the fuel filter, and finally the alternate inlet plug. If the plug is removed first, particles may come out of the fuel filter and contaminate the inside of the servo!
  - 6.2.2.2 Inspect the o-rings on all three of the components to ensure that they are not nicked, cracked, or damaged and replace them if they are. Lubricate the three o-rings, the inlet and alternate ports in the servo body, and the inside of the fuel inlet fitting with clean engine oil.
  - 6.2.2.3 Install the plug into the new location and torqued to the value noted in the torque specification table. Safety wire the plug to the servo body ensuring safety wire pulls in the direction to tighten plug.



## INSTALLATION AND DETAIL SPECIFICATION EX-5VA1® FUEL INJECTION SERVOS

- 6.2.2.4 Insert the filter into the fuel inlet port starting with the spring end first. The filter will slide in until the spring touches the plug.
- 6.2.2.5 Install the inlet fitting into its new location and torqued to the value in the torque specification table.

### **6.3 Servo Fuel Outlet and Alternate Fuel Outlet Fittings**

- 6.3.1 The servo has two possible outlet ports. One of the ports will have a flared AN #4 type fuel fitting installed. This port is called the “Outlet”. The other port is called the “Alternate Outlet” and is plugged with a fitting and safety wired to the servo body.
- 6.3.2 If the servo is supplied with an angled outlet fitting, it can be rotated if necessary. The outlet and alternate outlet fittings can also be swapped. Prior to installing a fitting, inspect the fitting’s o-ring for nicks, cracks, or other damage. If damaged replace with part number as found on the drawings. Lubricate the o-ring, fitting, and the port with clean engine oil, then install the fitting and torque to the value found in the torque specification table.

**7.0 Starting Procedures.** Steps on how to start the engine are located in Appendix A.

**8.0 Idle Speed and Idle Fuel Flow.** Steps on how to adjust idle speed and fuel flow are described in the Appendix B.

**9.0 Economy Cruise.** The EX-5VA1® servos come with a mixture control lever that is operated in the cockpit via linkage. It is used for leaning the fuel flow out during cruise (less than 75% engine power). How to properly lean out the engine during cruise is defined by the airframe and engine manufacturer.

**10.0 Rated RPM Fuel Flow Adjustment.** The required fuel flow (FF) at rated horsepower (HP) is defined by the engine and airframe manufacturers. Usually the desired FF creates an air/fuel ratio richer than best power in the range of 75-100% HP when the mixture lever is in the full rich position. This is to promote cylinder cooling and avoid detonation. The EX-5VA1® servo is shipped so that the FF falls within the engine manufacturer’s requirements. Engine life, performance, and economy can be dramatically affected by the FF. How well the engine is running is directly related to safety of flight. Precision Airmotive’s LLC Web Site has information and various links for assisting the aircraft operator in the determining if the engine is too rich or lean with the mixture lever in the full rich position.

**11.0 Fuel Leaks.** Whenever a fuel line, fuel fitting is changed, or moved always check to ensure the fuel lines are tight and that there are no fuel leaks. A slight fuel stain by the fuel nozzles is not unusual.





## INSTALLATION AND DETAIL SPECIFICATION EX-5VA1® FUEL INJECTION SERVOS

**12.0 Maintenance, Repair, and Overhaul.** Overhauls can only be done by Precision Airmotive LLC. Some minor repairs can be done by the customer but Precision Airmotive LLC should be contacted first, to get approval and guidance. Maintenance and overhaul requirements for the servo, flow divider, and nozzles are:

12.1 The time between overhaul (TBO) is the same as the TBO specified by the engine manufacturer for the engine on which the fuel servo was installed (up to a maximum of 2600 hours) or ten (10) years since the servo was placed in service or last overhauled, whichever occurs first.

12.2 The airplane's fuel filter needs to be maintained to ensure that the servo gets clean fuel. The fuel filter inside the servo is a last chance filter. This filter does not need to be checked or cleaned unless it is suspected that contaminants have entered the fuel line after the aircraft's fuel filter.

**13.0 Drawings.** Included are the drawings for a fuel system layout, EX-5VA1® servo, flow divider, and nozzles.

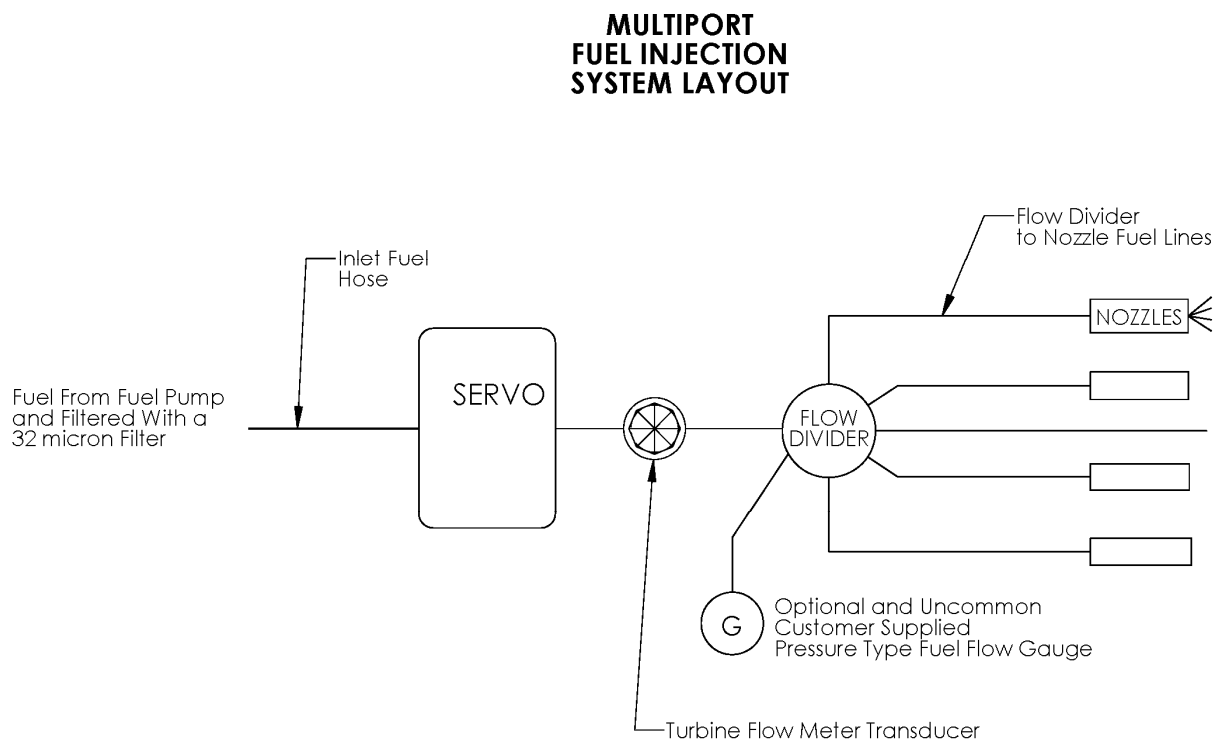



# INSTALLATION AND DETAIL SPECIFICATION

## EX-5VA1<sup>®</sup> FUEL INJECTION SERVOS

### NOZZLE

#### NOTES:

- 1) Install 1/8-27 NPT side of nozzle into each nozzle or primer port of cylinder head. Torque nozzle to value in torque specification table using a clean deep well 1/2" 6-point socket.
- 2) The letter "A" stamped on one flat of the wrenching hex is located 180 degrees from the air bleed hole in the nozzle body. When installing nozzles in primer ports it is desirable to have the "A" facing downward, but the correct torque should take priority during installation.
- 3) Attach fuel line to nozzle and torque fuel line union nut (AN805-2) to the value in the torque specification table.
- 4) Each nozzle and insert are a matched set, do not interchange inserts.

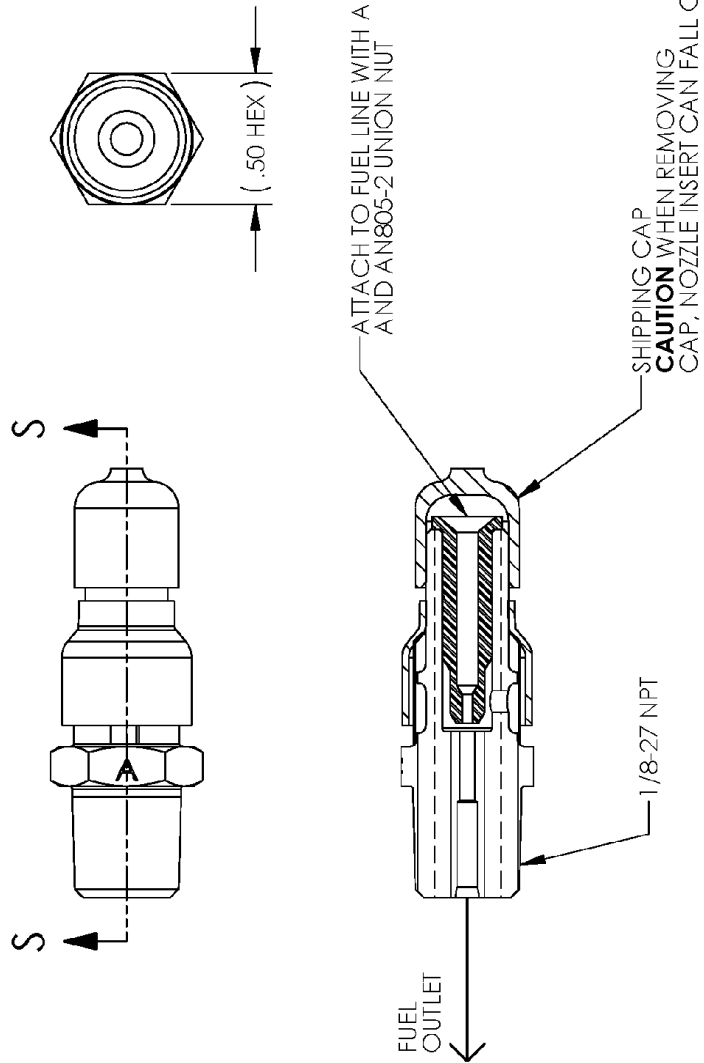



# INSTALLATION AND DETAIL SPECIFICATION

## EX-5VA1® FUEL INJECTION SERVOS

### FLOW DIVIDER MULTI-PORT FUEL INJECTION

**NOTES:**

- 1) Apply Loctite 569 hydraulic sealant to the second and third threads through 360 degrees on the 1/8-27 NPT side of the fittings that will be installed into the flow divider. Do not permit sealant to enter inside of hole or end of plug or fitting. Torque fittings per torque specification table.
- 2) Port labeled GAGE is for a special pressure driven fuel flow meter not normally used. Plug with 1/8-27 AN style plug.
- 3) Attach fuel line to fittings and torque fuel line union nut (AN805-2) to the value in the torque specification table.

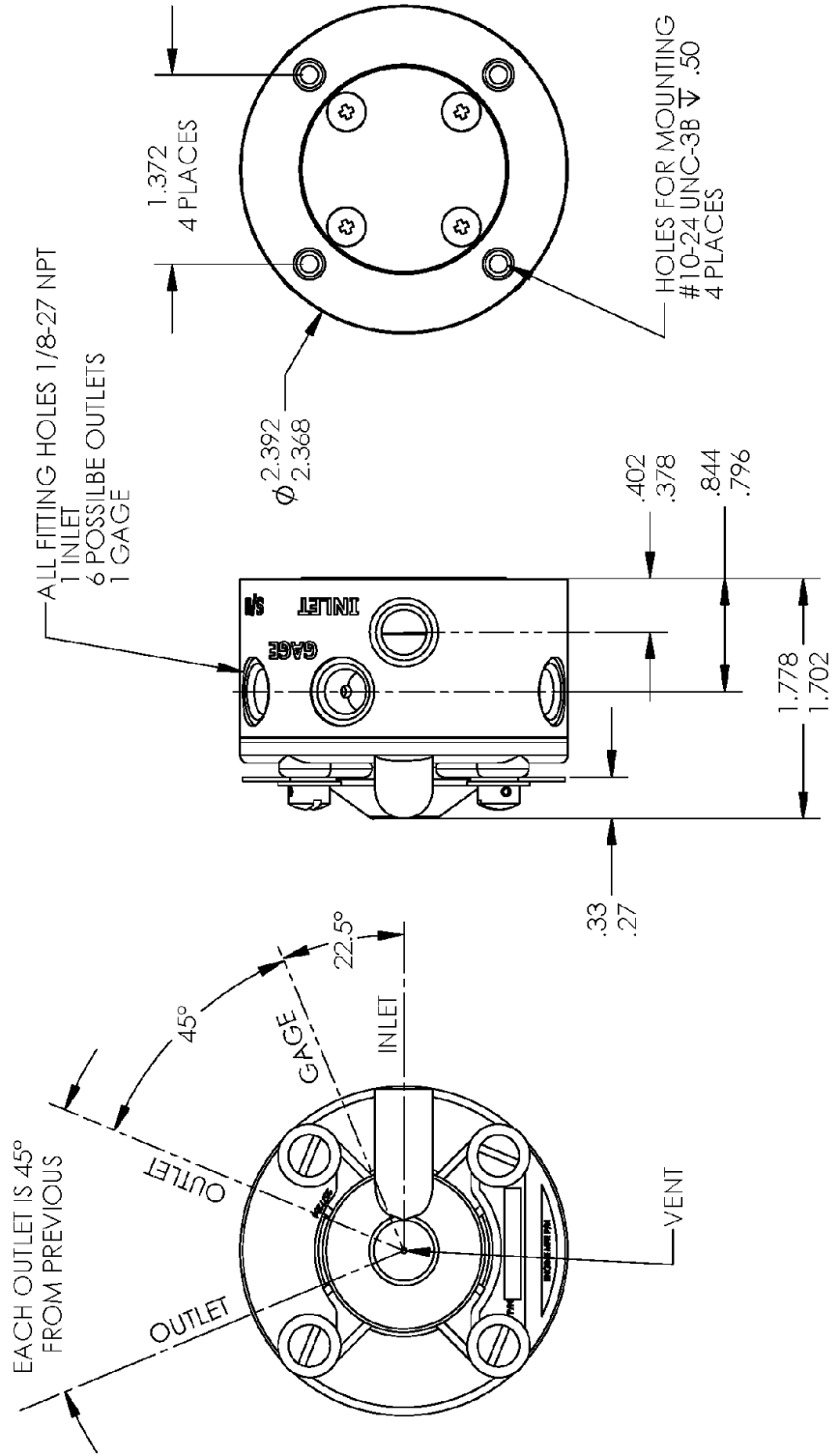



# INSTALLATION AND DETAIL SPECIFICATION

## EX-5VA1<sup>®</sup> FUEL INJECTION SERVOS

### EX-5VA1<sup>®</sup> SERVO

NOTES:

- MIXTURE & THROTTLE LEVER DIMENSIONS SUCH AS THICKNESS, OFFSET, LENGTH, AND CABLE LINKAGE HOLE DIAMETER DEPEND ON SERVO PART NUMBER. DIMENSIONS CAN BE FOUND BY GOING TO [PRECISIONAIRMOTIVE.COM](http://PRECISIONAIRMOTIVE.COM) UNDER SILVER HAWK EX SELECT "SUPPORT" AND THEN "DEFAULT LEVERS".

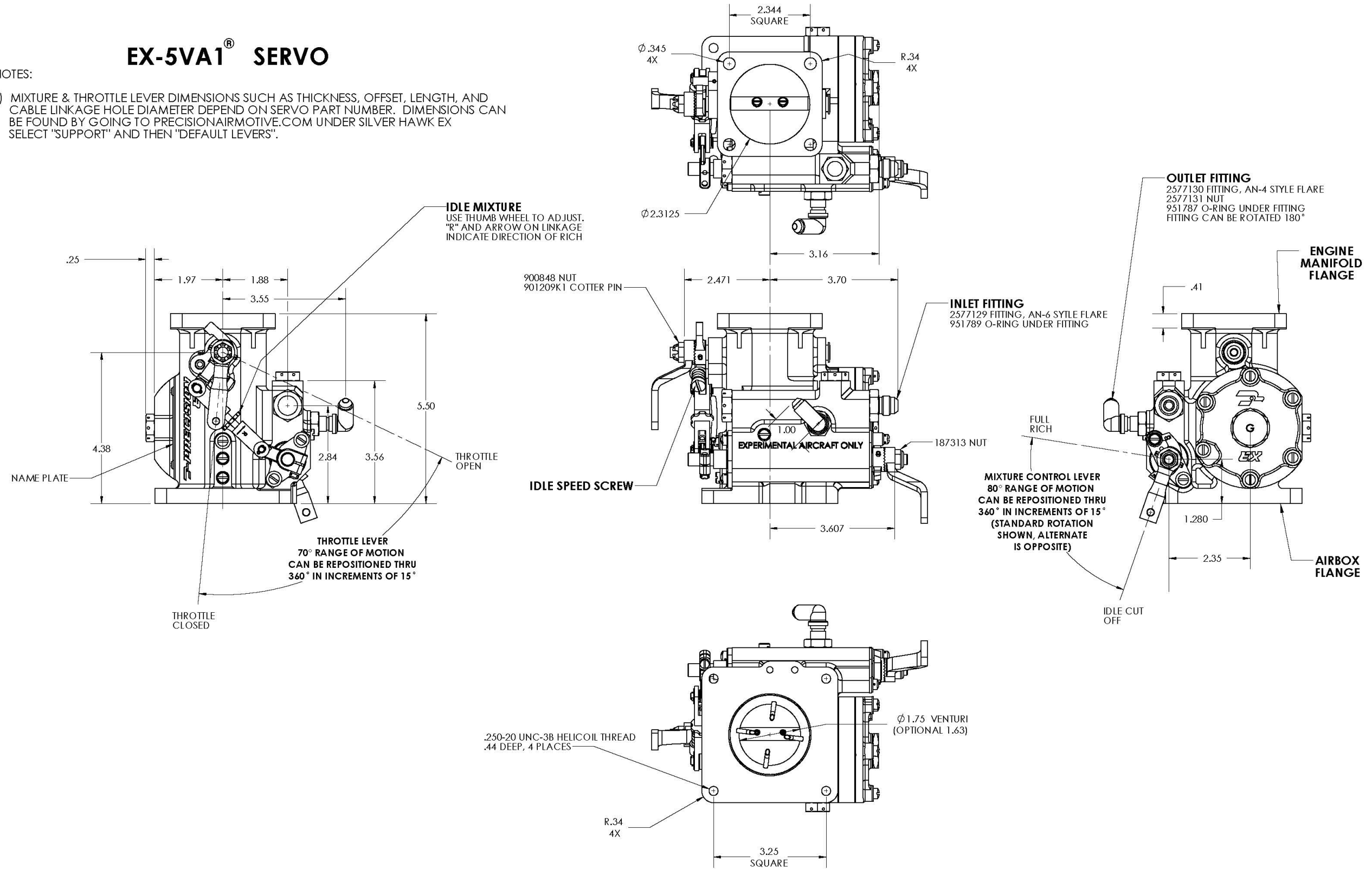



**INSTALLATION AND DETAIL SPECIFICATION**  
**EX-5VA1<sup>®</sup> FUEL INJECTION SERVOS**

**Section 14 Torque Specifications**

**Servo**

Object	Installation	Torque
Fuel Inlet Fitting	Into Servo	65-70 in-lbs
Alternate Fuel Inlet Fitting	Into Servo	65-70 in-lbs
Fuel Outlet Fitting	Into Servo	45-50 in-lbs
Alternate Fuel Outlet Fitting	Into Servo	45-50 in-lbs
Mixture Control Lever Elastic Nut	On Servo	90-100 in-lbs
Throttle Lever Nut	On Servo	See Below
<p>Torque throttle lever nut to 90 in-lbs and tighten further as required to install cotter pin. If alignment cannot be accomplished without exceeding 130 in-lbs, back off half a turn, then retighten. Occasionally it may be necessary to select a new part. Once the pin is inserted, bend the ends over.</p>		

**Flow Divider**

Object	Installation	Torque
Fuel Inlet Fitting	Into Flow Divider	45-65 in-lbs
Outlet Fittings	Into Flow Divider	45-65 in-lbs
Gage Port Fitting	Into Flow Divider	45-65 in-lbs
Outlet Fuel Lines	From Outlet Fittings to Nozzles	25-50 in-lbs, do NOT exceed 50 in-lbs
Mounting Bracket	On Bottom of Flow Divider	20-30 in-lbs

**Nozzles**

Object	Installation	Torque
Nozzle	Into Cylinder Head	60 in-lbs
Fuel Lines	From Flow Divider To Nozzles	25-50 in-lbs, do NOT exceed 50 in-lbs



## INSTALLATION AND DETAIL SPECIFICATION EX-5VA1® FUEL INJECTION SERVOS

### SECTION 15 TROUBLESHOOTING

**INSTALLATION:** It is absolutely necessary to install servo, flow divider, and nozzles per the engine and/or airframe manual for proper operation. Failure to do so may result in unsatisfactory operation, injury, or death.

**REMOVAL:** Before removing fuel injection components from engine for warranty consideration, and after verifying all other components work properly, troubleshoot the following symptoms:

PROBLEM	PROBABLE CAUSE	REMEDY
HIGH FUEL FLOW READING	PLUGGED NOZZLE IF HIGH FUEL FLOW IS ACCOMPANIED BY LOSS OF POWER, AND ROUGHNESS.	REMOVE AND CLEAN NOZZLES. A 20 MINUTE SOAK IN HOPPE'S #9 GUN CLEANING SOLVENT, A STODDARD SOLVENT RINSE AND BLOW DRY. CHECK SYSTEM FOR SOURCE OF CONTAMINATION.
	FAULTY GAGE.	CRISS-CROSS GAGES AND REPLACE IF NECESSARY. IF SINGLE ENGINE, REPLACE GAGE.
STAGGERED MIXTURE CONTROL LEVERS	IF TAKEOFF IS SATISFACTORY, DO NOT BE TOO CONCERNED ABOUT STAGGERED LEVERS BECAUSE SOME MISALIGNMENT IS NORMAL WITH TWIN ENGINE INSTALLATION.	CHECK RIGGING.
POOR CUT-OFF	IMPROPER RIGGING OF AIRCRAFT LINKAGE TO MIXTURE CONTROL.	ADJUST.
ROUGH ENGINE (TURBO CHARGED) AND POOR CUT-OFF	NOZZLE AIR BLEED HOLE (S) CLOGGED.	CLEAN OR REPLACE NOZZLES.
ENGINE WILL NOT ACCELERATE PAST A GIVEN RPM	OIL IN AIR CHAMBER.	REFER TO PRECISION AIRMOTIVE LLC SERVICE INFORMATION LETTER RS-40
ROUGH IDLE	SLIGHT AIR LEAKS INTO INDUCTION SYSTEM THROUGH LOOSE INTAKE PIPES OR DAMAGED "O" RINGS. USUALLY ABLE TO ADJUST INITIAL IDLE BUT ROUGH IN 1,000-1,500 RPM RANGE.	REPAIR AS NECESSARY
	LARGE AIR LEAKS INTO INDUCTION SYSTEM SUCH AS MISSING PIPE PLUGS, ETC. USUALLY UNABLE TO THROTTLE ENGINE DOWN BELOW 800-900 RPM.	REPAIR AS NECESSARY
	FUEL VAPORIZING IN FUEL LINES OR DISTRIBUTOR. ENCOUNTERED ONLY UNDER HIGH AMBIENT TEMPERATURE CONDITIONS OR FOLLOWING PROLONGED OPERATION AT LOW IDLE RPM'S.	<u>KEEP TEMPERATURES LOW BY:</u> - AVOID EXCESSIVE GROUND RUN. - RPM'S AS HIGH AS PRACTICAL. - COWL FLAPS OPEN WHEN PRACTICAL UPON RESTARTING HOT ENGINE, OPERATE AT 1,200-1,500 RPM FOR SEVERAL MINUTES TO REDUCE RESIDUAL HEAT IN ENGINE COMPARTMENT.



## INSTALLATION AND DETAIL SPECIFICATION EX-5VA1<sup>®</sup> FUEL INJECTION SERVOS

PROBLEM	PROBABLE CAUSE	REMEDY
LOW TAKE-OFF FUEL FLOW	FAULTY GAGE.	IN TWIN ENGINE INSTALLATION CRISS-CROSS GAGES. REPLACE AS NECESSARY. SINGLE ENGINE, CHANGE GAGE.
	STICKY FLOW DIVIDER.	CLEAN FLOW DIVIDER.
HARD STARTING	TECHNIQUE.	REFER TO AIRCRAFT MANUFACTURER'S RECOMMENDED STARTING PROCEDURE
	FLOODED.	CLEAR ENGINE BY CRANKING WITH THROTTLE OPEN AND MIXTURE IN ICO.
	THROTTLE VALVE OPENED TOO FAR.	OPEN THROTTLE TO POSITION APPROXIMATING 800 RPM.
	INSUFFICIENT PRIME (USUALLY ACCOMPANIED BY A BACKFIRE).	INCREASE AMOUNT OF PRIMING.
ROUGH ENGINE	MIXTURE TOO RICH OR TOO LEAN.	CONFIRM WITH MIXTURE CONTROL. A TOO RICH MIXTURE WILL BE CORRECTED AND ROUGHNESS DECREASED DURING LEAN-OUT WHILE A TOO LEAN MIXTURE WILL BE AGGRAVATED AND ROUGHNESS INCREASED. ADJUST IDLE TO GIVE A 25-50 RPM RISE @700 RPM.
	PLUGGED NOZZLE (S). USUALLY ACCOMPANIED BY HIGH TAKE OFF FUEL FLOW READINGS.	REMOVE AND CLEAN NOZZLES. A 20 MINUTE SOAK IN HOPPE'S #9 GUN CLEANING SOLVENT, RINSE WITH STODDARD SOLVENT AND BLOW DRY. CHECK SYSTEM FOR SOURCE OF CONTAMINATION.
	SLIGHT AIR LEAK INTO INDUCTION SYSTEM THROUGH MANIFOLD DRAIN CHECK VALVE. USUALLY ABLE TO ADJUST INITIAL IDLE BUT ROUGH IN 1,000-1,500 RPM RANGE.	CONFIRM BY TEMPORARILY PLUGGING DRAIN LINE. REPLACE CHECK VALVE AS NECESSARY.
	AIR LEAK IN FUEL LINE FROM TANK TO SERVO	CONFIRM BY CONNECTING CLEAR TUBING BETWEEN SERVO AND FLOW DIVIDER AND WATCH FOR AIR BUBBLES. LOCATE AND CORRECT SOURCE OF LEAKAGE. MAY INCLUDE BOOST PUMP OR MAIN PUMP SEAL LEAKAGE.

IF ALL THE ABOVE ITEMS HAVE BEEN ELIMINATED AND THE SERVO IS UNDER WARRANTY, IT MUST BE SENT TO PRECISION AIRMOTIVE LLC FOR REPAIRS.

**NOTE:**

**THE USE OF NON-AVIATION GRADE FUEL VOIDS ALL WARRANTIES.**



**INSTALLATION AND DETAIL SPECIFICATION**  
**EX-5VA1® FUEL INJECTION SERVOS**

**SECTION 16**  
**FUEL CONTROL TROUBLESHOOTING**  
**RUN-UP SHEET**

Date: \_\_\_\_\_

Aircraft Registration: \_\_\_\_\_ Fuel Control Model: \_\_\_\_\_

Aircraft Model: \_\_\_\_\_ Fuel Control P/N: \_\_\_\_\_

Engine Model: \_\_\_\_\_ Fuel Control S/N: \_\_\_\_\_

Engine TSO: \_\_\_\_\_ Fuel Control TSO: \_\_\_\_\_

	LEFT	RIGHT		LEFT	RIGHT
Idle Speed	_____	_____	Mag Drop	LT _____	_____
Idle Cut Off	_____	_____		RT _____	_____
RPM Rise					
Static RPM	_____	_____	Engine Response	_____	_____
Fuel Flow	_____	_____	Fuel Selector	_____	_____
CHT and/or EGT	_____	_____	(All Positions)		

**1000RPM**

Fuel Flow Boost Off \_\_\_\_\_

Fuel Flow Boost On \_\_\_\_\_

**2000 RPM**

Fuel Flow Boost Off \_\_\_\_\_

Fuel Flow Boost On \_\_\_\_\_

Additional Comments \_\_\_\_\_

For technical assistance, please contact Precision Airmotive LLC Product Support.





**INSTALLATION AND DETAIL SPECIFICATION**  
**EX-5VA1<sup>®</sup> FUEL INJECTION SERVOS**

**APPENDIX A**  
**Starting Procedures**

The following starting procedures has been proven successful; however, if there is conflict, information given in the Aircraft Operation Manual should be followed.

**1. Cold Starts**

- 1.1. Place mixture control in idle cut-off position.
- 1.2. Set throttle to 1/8 open position.
- 1.3. Master switch –ON-.
- 1.4. Boost pump switch –ON-.
- 1.5. Move mixture control to FULL-RICH until fuel flow indicator reads 4 to 6 GPH then immediately return mixture control to cut-off position.

NOTE

On installations where a fuel flow indicator  
is not used allow 4 to 5 seconds in place of  
reading 4 to 6 GPH on the gage.

- 1.6. Engage start - - when engine starts move mixture control to full rich position.

**2. Warm Starts**

Use the same procedure as for cold starts except the boost pump may be left “off” and step 1.5 eliminated. **DO NOT PRIME.**



**INSTALLATION AND DETAIL SPECIFICATION**  
**EX-5VA1<sup>®</sup> FUEL INJECTION SERVOS**

**APPENDIX B**

**SUBJECT: Idle Speed and Mixture Adjustments for EX-5VA1<sup>®</sup> Fuel Injection Systems**

**PURPOSE:** To provide comprehensive idle speed and mixture adjustment procedures.

- A. **EFFECTIVITY:** All aircraft using EX-5VA1<sup>®</sup> fuel injection systems.
- B. **DESCRIPTION:** The following procedures may be used to inspect and set idle speed and mixture settings. The recommended interval between inspections is every 25 hours for the first 100 hours and at every 100 hour or annual inspection thereafter.

C. **DETAILED INSTRUCTIONS:**

Refer to the aircraft maintenance manual for idle speed and mixture setting procedures and limitations. If the aircraft maintenance manual has no procedures and limitations, the following instructions should be followed:

1. Start the engine and warm up in the usual manner until the oil temperature is in the 140 to 180 degrees F range. To eliminate any possible effects from vapor formation, the engine should be cold prior to startup (see paragraph C.13). The relationship of the aircraft to the direction of the prevailing wind will have an effect on the propeller load and its RPM; hence, it is advisable to make the idle setting with the aircraft crosswind.
2. Run the engine at the RPM recommended in the aircraft flight manual for magneto check for a minimum of 30 seconds to clear engine before performing the following checks.
3. Check magnetos in accordance with instructions furnished in the aircraft operational manual. If the “mag-drop” is excessive, check for fouled plugs. If the “mag-drop” is normal, proceed with idle adjustment.
4. Move the cockpit throttle control to idle and release the control. Set throttle stop screw so that the engine idles at the airframe manufacturer’s recommended idling speed. If the airframe manufacturer’s information does not have an idle RPM setting, 700 RPM - 750 RPM is recommended. If the RPM changes appreciably after making idle adjustment during the succeeding steps, readjust the idle speed to the desired RPM.



## INSTALLATION AND DETAIL SPECIFICATION EX-5VA1<sup>®</sup> FUEL INJECTION SERVOS

5. When the idle speed has stabilized, move the cockpit mixture control very slowly toward the “idle cut-off” position. If the aircraft is equipped with a vernier mixture control, use the vernier. If the aircraft does not have a vernier mixture control, move the control in very small increments and allow a few seconds for the engine to respond between mixture control movements. Observe the tachometer for changes in engine RPM during this leaning process. Continue leaning until a definite drop in engine RPM is indicated on the tachometer. The maximum observed RPM during the leaning process is “best power” RPM. An increase in RPM while “leaning out” indicates the mixture is richer than best power. An immediate decrease in RPM (not preceded by an increase) indicates the idle mixture is set too lean. Caution must be exercised to return the mixture control to the “Full Rich” position before the RPM can drop to a point where the engine cuts out.
6. The optimum idle setting is one that is rich enough to provide a satisfactory acceleration under all conditions and lean enough to prevent spark plug fouling or rough operation. A rise of 10-40 RPM will usually satisfy both of these conditions.
7. If the above indicates that the idle adjustment is too rich or too lean, turn the idle mixture adjustment in the direction required for correction, and check this new position by repeating the above procedure. Make additional adjustments as necessary until a check results in the desired RPM rise. Each time the adjustment is changed, the engine should be run up to the RPM used for the magneto check to clear the engine before proceeding with the RPM check.
8. The actual idle mixture adjustment is made by the lengthening (richening) or shortening (leaning) of the linkage between the throttle lever and idle valve lever. The center screw assembly has right hand threads on both ends but one end has a No. 10-24 thread and the other end has a No. 10-32 thread. The screw assembly also has a thumb wheel or a hex nut in between the coarse and fine threads to be used as a means of adjustment. For easy reference, consider only the coarse thread end. When it is turned out of its block, the linkage becomes longer and a richer mixture is provided. When it is turned into its block, the linkage is shortened and a leaner mixture is provided. Many servos have an “R” and an arrow engraved on one of the links to indicate which way to turn the screw assembly to enrichen the mixture.
9. A major adjustment is available for use when the screw assembly bottoms out on either of the blocks. If the idle adjustment is almost satisfactory, measure the distance between the two blocks. Disconnect the spring (when applicable) from the most accessible linkage pin and remove the linkage pin, wave and flat washer. Turn the block and adjustment screw until the adjusting wheel is centered and the distance between blocks is as previously measured. Reinstall the linkage pin, flat, and wave washer and spring (if used). There is now additional adjustment range and the reference point is retained.
10. Make the final idle speed adjustment to obtain the desired idling RPM with closed throttle.
11. The above method aims at a setting that will be suitable for a normal range of atmospheric conditions. In case the setting does not remain stable, check the idle linkage; any looseness in this linkage would cause erratic idling. In all cases, allowance should be made for the effect of weather conditions and field altitude upon idling adjustment.



## **INSTALLATION AND DETAIL SPECIFICATION** **EX-5VA1<sup>®</sup> FUEL INJECTION SERVOS**

12. Idle speed and mixture adjustments made according to this method should require very little further attention except for significant variations in temperature and altitude. Under some conditions the mixture rise may fall outside of the values set during adjustment. It is normally acceptable to have no rise as long as the RPM remains within  $\pm 50$  RPM of the original setting. It is also normally acceptable to have a rise of up to 75 RPM as long as the engine continues to run smoothly.
13. If the system has been set up in accordance with the above instructions and the mixture does not meet the criteria set in paragraph C.12 after a short period of time, further troubleshooting is in order. If the system is set in accordance with this letter (prior to extended engine runs or flights), and the mixture does not meet the criteria after flight (especially in warm weather), vapor formation may be indicated. If no other discrepancies are found, the servo should be removed and sent to an approved repair facility for evaluation.