

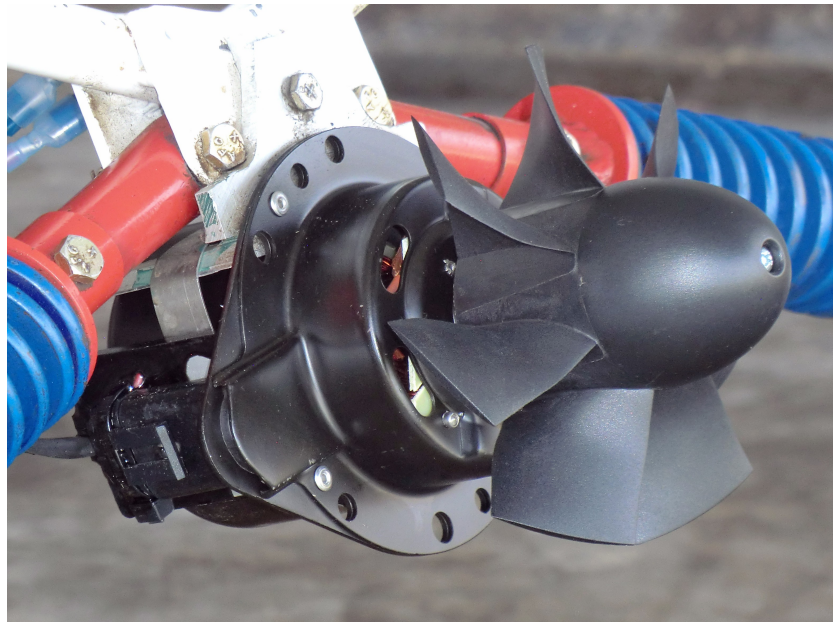

JMH Innovations LLC
P.O. Box 786
Valley View TX 76272
jehardy@ntin.net
<http://www.ntin.net/jhardy>

GenniPod
Gen II



Use of this product is intended strictly for the experimental use of the Purchaser. The purchaser, actual user, or agent, assumes all responsibility for it's fitness and risk of use.

Introduction

Thank You for purchasing a Time proven product from JMH Innovations LLC. We expect this product to meet your needs if used and installed within the design specifications.

The staff of JMH have received many many requests for a commercially available version of this generator system dating back to the year 2000. Surprisingly this system seemed to bring as much, if not more, attention than the pretty little craft it was mounted to, regardless of where it landed! 28 hours of flying involved in a trip to Oshkosh and back, low battery charge was never observed. Many (20) take off and landings taxi etc. . . .

History and Design Goals

We hope you have studied the specs and found the abilities of this system consistent with your needs. The prototype was produced to provide for the maintenance of a battery supporting the Point/Condenser/Coil ignition system of a VW engine installed on a FFP Youngster "V". First goal - 12 volts DC at 75 mph with a 4 amp load: Why?: the target aircraft cruise speed was 75 mph with a range of 40 V_{so} to 110 V_{ne} (mph).

Recently, the supply of the original commercially produced impeller has ceased. After much searching, a replacement impeller was found that would allow consistent pricing, supply, and performance.

A great feature of this impeller is that it may be reversed! This will allow it to be reversed to accommodate various speed ranges. Slow speed range to 80 mph (left) and 110 mph (right) in faster speed mode, as pictured below.



Use of this product is intended strictly for the experimental use of the Purchaser. The purchaser, actual user, or agent, assumes all responsibility for it's fitness and risk of use.

Test aircraft Loads were approximately as follows. Yours may vary depending on many factors.

Common loads

Fuel Pump

VW In Line Fuel pump. 1.6 amps (occasional fuel transfer use only)

Ignition

VW Stock ignition. points, condenser, blue coil

- Engine Off Aprox. 3.5 amps
- Engine at Idle Aprox. 2.5 amps
- Engine at Cruise RPM. 0.95 amps

GPS

Garmin Pilot III 0.5 watts

ICOM

- Squelched 55 mA
- Receive 400 mA
- Transmit 1.0 amp

All added up, we are at approximately, 48 watts (4 amp) thus the target of design output. **The GenniPod was never intended to provide primary or sole power for ignition or maintenance of flight.**

Testing

This system was designed for an application using a 7 - 12 amp/hr lead acid battery. By nature they will absorb and stabilize a majority of all surplus volts/amps we may produce. If our aircraft always flew at an exact speed and exact load, then a system could be designed without regulation. That is not the nature of our planes. (not fun ones that is)

Use of this product is intended strictly for the experimental use of the Purchaser. The purchaser, actual user, or agent, assumes all responsibility for it's fitness and risk of use.

Initially - A completely separate but equal electric system and load was created and installed for testing. Ground/taxi testing was first found to provide usable voltage through prop blast. Idle power obviously would allow the GenniPod to drop off line. Take off and cruise provided all required voltage and load expectations. no notable temp rises were noted in either the battery or regulator's components after considerable cruise time, at varied speeds. Lastly engine idle and low speed behavior was explored. It was discovered that with the generator mounted well within the arc of the propeller, when idled, airflow was blocked sufficiently to pretty much drop the generator off line.

Recent testing on lower speed aircraft finds that at approximately 60 to 70% of the prop radius from the hub, provides the best Prop generated air flow. (Leonard Milholland Double Eagle)

The Final phase of Testing was to remove all test circuits and tie the generating system directly to the ship's power grid. Taxi, take off, cruise, decent, high speed, low speed, tests were made. There were no problems found or changes made to the original system's circuits or design.

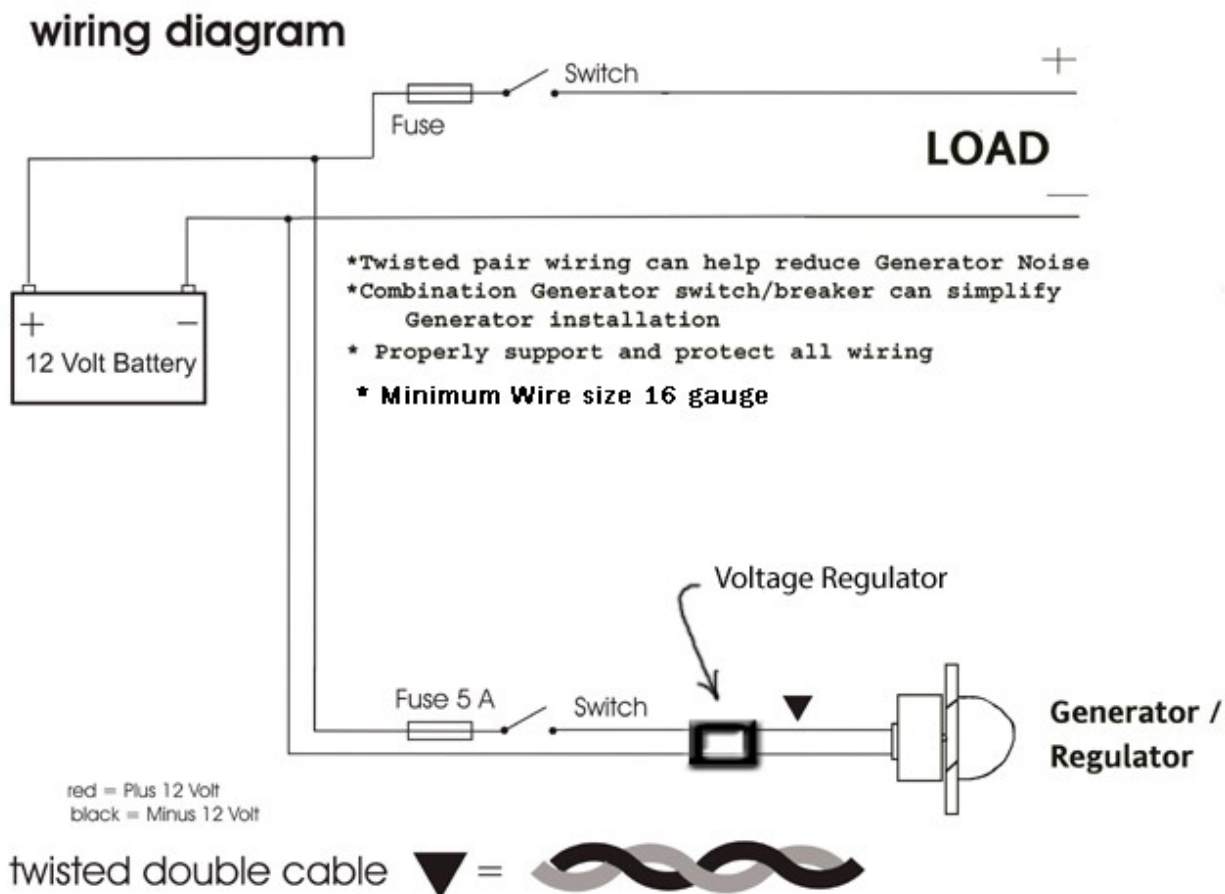

Use of this product is intended strictly for the experimental use of the Purchaser. The purchaser, actual user, or agent, assumes all responsibility for it's fitness and risk of use.

Installation considerations

Since there are numerous mounting configurations, there was no way all options and installation methods could be foreseen. Thus the mounting of your generator system must be left to your creativity. The initial test aircraft had its generator mounted to a 3/16" aluminum angle, with 2 Stainless hose clamps. Simplicity, and strength will always win in the end.

- Good air flow (I know, but I had to say it!)
- **Some Airflow should be allowed to the regulator as well**
- What you are mounting to must be able to take air load and vibrations
- Gear legs
- Gear supporting structure
- Fuselage surface

Location considerations

- Clean air will give you less vibration
- Centerline will give less pitch or yaw deflection from air loading/drag on the unit

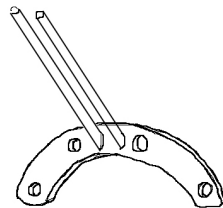

The Generator body can be mounted different ways. The flange on the Body is adequate for mounting strength as an option.

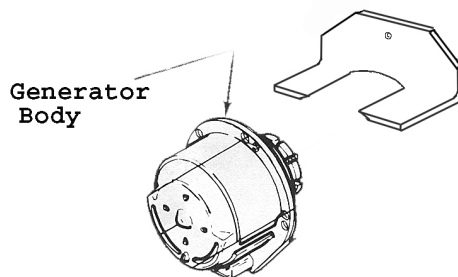

2" x 3/16 Angle Aluminum Saddle cut to accept Generator body. Angle aluminum then attached to Generator body using 3" Hose clamps. Angle mount then bolted to aircraft

Use of this product is intended strictly for the experimental use of the Purchaser. The purchaser, actual user, or agent, assumes all responsibility for it's fitness and risk of use.

Other thoughts to consider

- Breaker or fuse (consider 5 amp breaker switch)
- Wire routing
- Wire chafing protection
- Battery location, and mount strength
- C.G.
- In case of impeller failure, what might be damaged
- On the ground, Do not charge your battery with the GenniPod switch on so that the regulator may have higher voltage exposure.
- Switching between batteries, or “On and Off” in flight may cause regulator failure.

Maintenance, preflight, condition inspection

There is generally no maintenance for your generator system. All components are chosen to assure dependability in normal use. like any aircraft component preflight of your generator system is always important: It is always important to maintain the health of your battery and not depend only on the the occasional flight with the GenniPod! I keep my batteries on “battery Tender” chargers at all time when not in flight. Will this generator support the operation of your engine after a total battery loss? Possibly, however, that is not the deigned purpose of this system!

Generator	Mounting solid and unchanged
Impeller	<ol style="list-style-type: none">1. Look for excessive play either fore/aft or a wobble in the blades that may indicate loose prop or generator bearing wear2. Nicks and cracks
Wiring	Loose frayed wires
Battery	<ol style="list-style-type: none">1. Check voltage engine off2. Check fluid levels3. Check cleanliness
Spinner	<ol style="list-style-type: none">1. Nicks and cracks2. Tracking true

Use of this product is intended strictly for the experimental use of the Purchaser. The purchaser, actual user, or agent, assumes all responsibility for it's fitness and risk of use.

Operation

Once installed and fully tested to your satisfaction, you can pretty much forget your generator is installed. Prudence of flight will of course require constant observation of your aircraft's systems, obviously including the electrical system. Your first and most telling instrument for your generator system will be your volt meter. If your voltage is anything less than 12.5 volts, only one of the three issues may be causing a problem..

Generator Failure	Assume you are now running strictly on battery. Know how long your battery will support your critical systems and land before that time is up. An older battery will not give you the duration that you received when your battery was new. Be able to load shed quickly to critical systems. I have one switch that powers voltmeter and ignition, the other brings the ancillary needs. hour meter, fuel gauge, power for fuel transfer pump, gps, ICOM navcom
Popped Breaker	Only reset if required for safety of flight. Once on ground try to determine cause and rectify
Overload	Reduce load requirements. Not a "bad" situation, just realize, that you might be draining your battery.
Battery Inop	For the GenniPod regulator to release power to the battery, it MUST see the battery's voltage above approximately 10 volts.

Disassembly

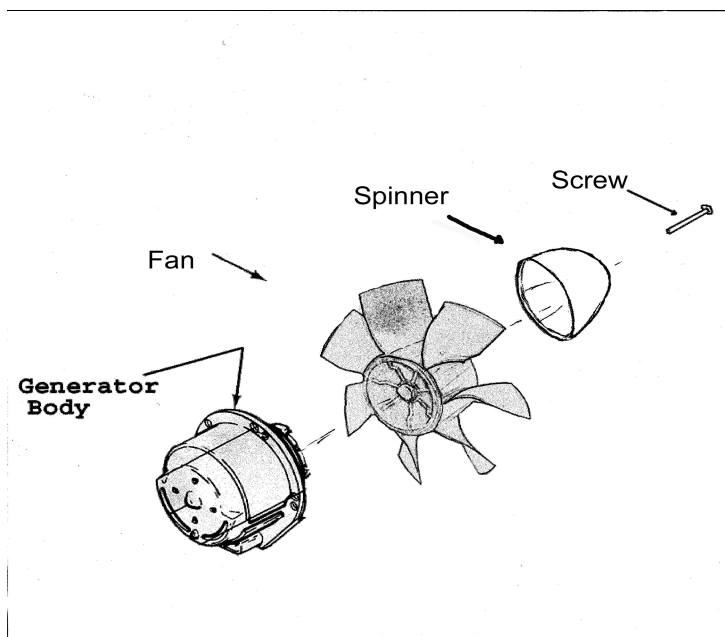

Use of this product is intended strictly for the experimental use of the Purchaser. The purchaser, actual user, or agent, assumes all responsibility for it's fitness and risk of use.

Your generator system will come assembled and ready to mount to your airframe. Removing the propeller and spinner assembly may assist your efforts in accessing the body of the generator for mounting purposes.

- To remove the spinner, a Phillips screw driver rotated **counter clockwise**, will allow removal spinner cone.
- To remove the fan blade from the generator is a bit more difficult. **FIRST** thing to recognize is that the Impeller is screwed onto the generator body with **LEFT HAND THREADS**. You must stop the rotation of the shaft by inserting, something into a vent hole (preferably non metallic) that will slide into the gaps in the rotor. Once you have the rotor secured, you can rotate the fan, **CLOCKWISE**, to loosen. Though this is not the natural way to “unscrew” something, it is essential to assure it will not come loose during operation.
- Of course the opposite is required for reassembly. Hand tight is all that is required. Great force will only cause damage.

Parts list

- Generator Body
- Prop
- Spinner cone
- Screw
- Regulator
- manual

Specifications

Design specifications and capabilities based on a 75 mph cruise speed.

Generator

Airspeed

- This system has been tested to the max of 110 mph. (If your aircraft will be at, or above these speeds, contact the manufacturer.)

Use of this product is intended strictly for the experimental use of the Purchaser. The purchaser, actual user, or agent, assumes all responsibility for it's fitness and risk of use.

Voltage

- 13.5volts and 4 amps.
Actual output is dependent on airspeed. (Faster a bit more, slower a bit less.)

Regulator

Maximum Input

voltage = 55 VDC

Maximum Output

13.5 volts at 8 amps (8 amps is not a design target, only the capability to handle a bit more power if momentary airspeed over 75 mph is reached)

- A point to consider is that 13.5 volts is the voltage the regulator targets. If the regulator while charging your battery detects 13.5 volts, it will shut off. It constantly rechecks for battery voltage. With this in mind, your volt meter probably will not be fast enough to display to you the 13.5 volts it sees.

Assembly weight 2 pounds 8.72 oz

Spinner	0.40oz
Spinner Screw	0.12oz
Impeller	2.50oz
Generator body.	2 lbs 4.50oz
Regulator	1.20oz

Manufacturer's Note

Every GenniPod is made by hand, one at a time. Every attempt is made to assure a safe and aesthetically pleasing product. The required modifications of parts used in other applications are substantial, and labor intensive. There will be, the occasional imperfection or slight scratch on an item. If the manufacturer felt in any way an imperfection would put an item at risk of longevity, meeting specs or safety, the part would have been scrapped.

Any modifications to the GenniPod are done at the purchasers risk. Painting of the GenniPod body, should be considered a non event to its operation. Any modification or painting of the Impeller should be considered a significant modification as I don't know what the chemical interaction with the impeller's resins may bring forth. Balance is also something that could be an issue in painting the impeller.

Use of this product is intended strictly for the experimental use of the Purchaser. The purchaser, actual user, or agent, assumes all responsibility for it's fitness and risk of use.



Regulator is carefully plugged into the Generator body as seen Above. Press in place using the the back end of the module plug until latch clip is properly seated. Do not force! If there is any issue, check the alignment of the tangs of the plug exiting the GenniPod body.